

污泥濃縮機 Slurry Thickener

周邊附屬設備參考配置圖

Allocation schema for peripheral equipment

◆ RDT系列 series

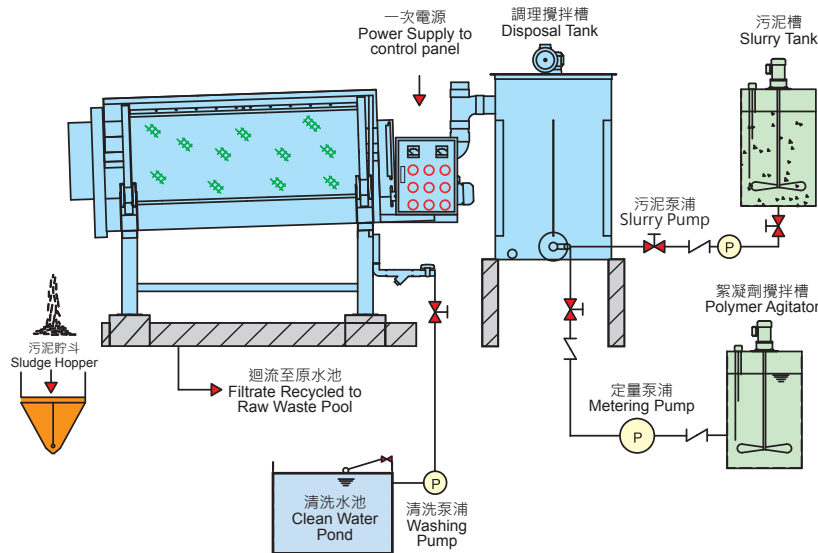

◆ SBT系列 series

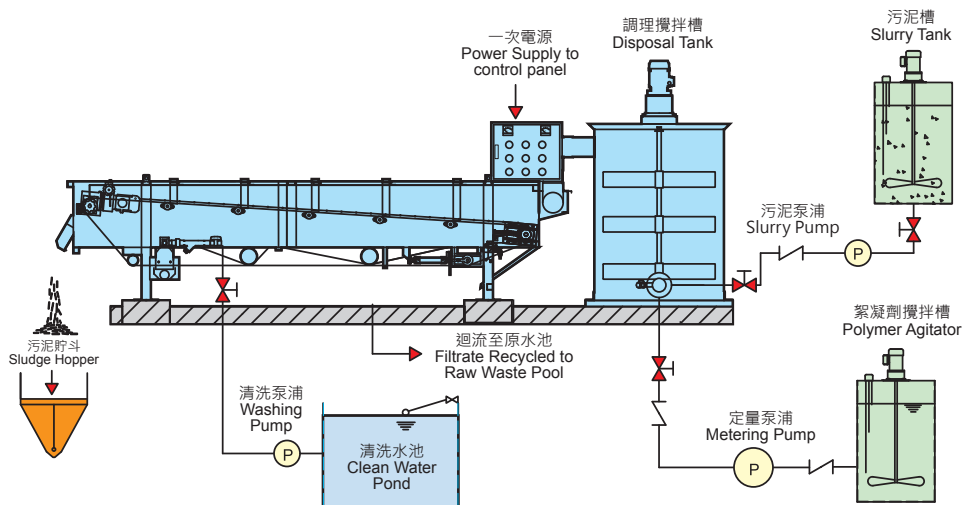

用途

- 各種工業及城市下水道、水肥、淨水廠...等污泥減量預濃縮處理。
- 各種工業紙漿、纖維、化工、食品、塑料、冶金礦業...等工業製程中固、液分離處理。
- 在食品工業釀造、味噌、製餡、澱粉及各種加工製程中原料過濾回收處理。
- 製酒業、醱製釀造業的渣滓顆粒過濾去除及水菓、蔬菜加工業之固、液分離。
- 自來水進水前過濾、雨水過濾回收。

Usages

- The pre-thickening for the various industrial waste slurry, city sewer, excretion, water purifying...etc.
- For the solid and liquid separation of the industrial processing treatment of the paper & pulp, fiber, chemical, plastic, metallurgy, mining...etc.
- For the materials' process filtering-recovering of the brewing, flavoring, stuffing, starch factory and the various food-processing factory.
- The filtering-removing of the dross pellet of the winery industry, pickled industry and the solid-liquid separation of the fruit processing industry, vegetable processing industry.
- The filtering before tap-water intaking, the filtering-removing of the rain water.